

MEEF

CONTRACT

safe+dy
p
d



Anti-bacterial powder coat using:





1



POD
W95" x D61" X H91"

2



BED
W81" x D38" X H20"

3



SIDE CABINET
W18" x D17" X H29"

4



LAMP
W16" x D16" X H2"

5



CURTAIN
W95" x D2" X H91"

PROPOSED USE



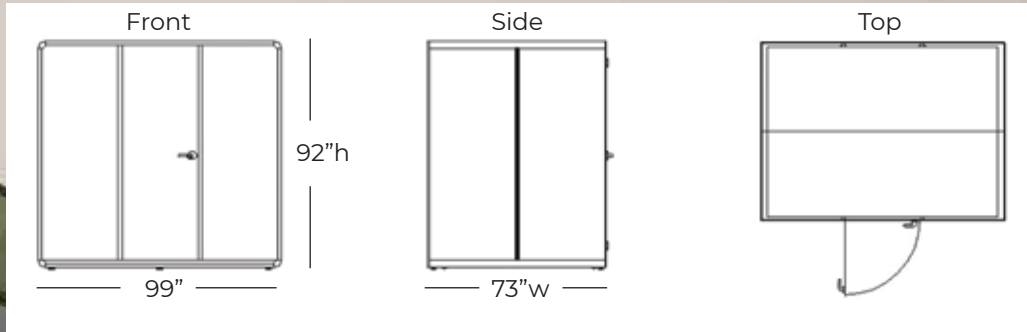



- Integrated positive and negative air treatment system
- 8x 98 CFM negative exhaust blowers providing indoor air circulation
- 8x 98 CFM positive exhaust blowers with 4-layer continuous filters providing continuous clean air
- Exhaust outlet may be connected with an external hospital centralized sterilized air system
- Optional exhaust outlet can be equipped with a biomedical ultraviolet sterilizer (inquire prior to purchasing)

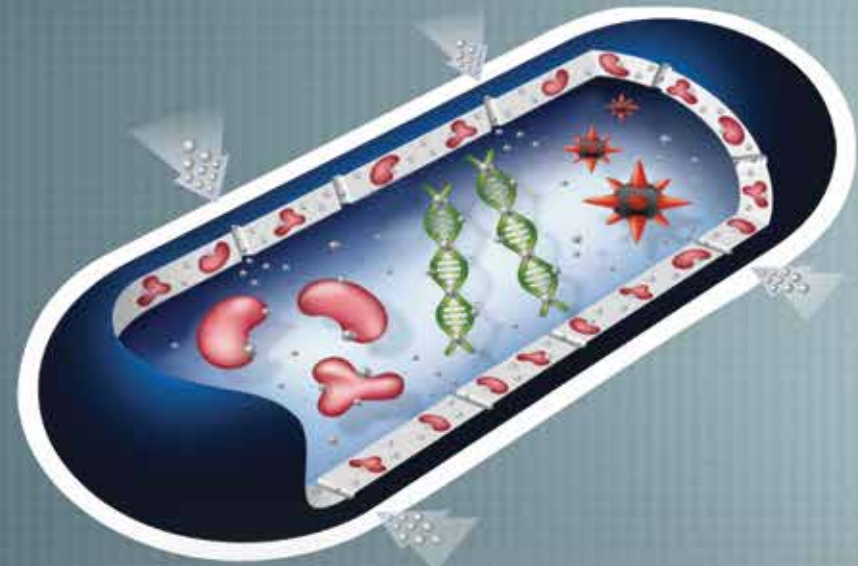

- safetypod™ is fabricated using high quality steel and aluminum with a fire retardant zero formaldehyde carbon polymer acoustic inner
- Exterior is finished with an anti-bacterial powder coating with Akzo Nobel BioCote technology
- Tempered glass windows and aluminum framed door assisting with additional sound proofing
- Powder is adaptable to 100-240V/50-60Hz and a 12V-USB power supply system offering multiple power requirement options
- Terminal access to connect to emergency broadcast system in addition to television terminal hook ups



High mobility

ball bearing casters to move and locking feet once placed



Sound insulation

shielded double wall structure for sound absorption



Air system

4-layer independent filters to help protect against bacteria and virus spread



Independent lighting

integrated low heat 4000k LED lighting





JETT
VERIFICATION OF

CE

JETTS SAFETY CO. LTD
115, Vignetteska Street, Vignetteska, Bratislava
SK 821 02 Bratislava

Aufbauübersicht für elektrische und elektronische Kompo-
Data form for electrical and electronic component

Hersteller: JETT SAFETY CO. LTD
Produkttyp: ...
Material: ...
Hersteller-Teil-Nr.: ...
Material-Teil-Nr.: ...

Bestandteil	Bezeichnung	Menge	Einheit
...

SGS

MEMO (DIN)

Produkt: ...
Material: ...
Hersteller: ...

SGS

Safenet Limited
Bentley Garage, Bedford, Bedfordshire, MK45 2JQ, UK

Certificate of Conformity

Safe Special Wire & Cable (RuffinWire) Co., Ltd.

1. The product identification system complies with the relevant provisions of the CE marking requirements of the EU Directive 2014/53/EU.

CE

CE

CE

TÜV

CERTIFICATE

Product conformity (Fixed Scaffolding)

TÜV

CE

Statement of Compliance

JETTS

CE